

E56 Pancake Inductive Proximity Sensors

Contents

Overview	3-64
Model Selection, Sensors	3-65
Model Selection, Compatible Connector Cables	3-66
Wiring Diagrams	3-66
Specifications	3-67
Dimensions	3-67

The Cutler-Hammer® E56 Pancake from Eaton's electrical business is a high performance inductive proximity sensor. The E56 Pancake provides greater sensing ranges than other inductive sensor package types.

The E56 Pancake family provides convenience and ease of wiring with auto-configurable, complementary outputs. (Auto-configurable outputs automatically detect an NPN or PNP output configuration and switch the sensor accordingly, without user intervention.) Power and output LEDs make troubleshooting much easier than conventional proximity sensors, which usually only feature output LEDs. These convenience features, combined with the performance of the E56 Pancake, make it an excellent inductive sensing solution for applications requiring an extremely rugged, long-range sensing solution.

Approvals



Long Range Inductive Sensors Designed for Use in Heavy-Duty Industrial Environments

Range Adjustment Pot on Medium and Large Models

Power and Output LEDs for Status Indication



Micro-Connector, Mini-Connector or Screw Termination Wiring Options

Three Package Sizes with 50, 70 and 100 mm Ranges



Product Features

- Longest inductive sensing ranges available (up to 100 mm)
- Three sizes to meet your application needs, with maximum ranges of 50, 70 or 100 mm
- Complementary outputs (1 N.O. / 1 N.C.) on 4-wire DC models
- Auto-configure output technology on 4-wire DC models, which automatically detect how the sensor has been wired (NPN or PNP) and switch the sensor without user intervention
- Small diameter, 2-wire AC/DC models feature a selector switch inside the housing, enabling output contacts to be used as either N.O. or N.C.
- Robust design featuring vibration and impact-absorbing potting compound
- Ideal for extreme temperatures or high pressure washdown environments

Typical Applications

- Heavy-duty trucks, cranes and machinery
- Steel mills
- Pipe and rod manufacturing
- Automotive manufacturing
- Amusement parks

Model Selection — E56 Pancake Sensors

	Voltage Type	Output Configuration	Output Contacts	Shielding	Sensing Range	Connector Style	Catalog Number
2-Wire Sensors							
	20 – 250V AC 20 – 60V DC 45/65 Hz	—	N.O. or N.C.	Unshielded	1.57 inches (40 mm)	Screw Terminals	E56CDL40A2
		—	N.O. or N.C.	Unshielded	2 inches (50 mm)	Screw Terminals	E56CDL50A2E
		—	N.O. or N.C.	Unshielded	2 inches (50 mm)	3-Pin Mini-Connector	E56CDL50A2EB1 ☹
	90 – 260V AC 20 – 60V DC 45/55 Hz	—	N.O.	Unshielded	2.75 inches (70 mm) ①	3-Pin Mini-Connector	E56CAL70B1S1 ☹
		—	N.O.	Unshielded	3.94 inches (100 mm) ①	3-Pin Mini-Connector	E56CAL100B1S1 ☹
DC 4-Wire Sensors							
Small Diameter (79 x 79 x 39 mm) 	10 – 42V DC	NPN / PNP Autoconfigure ②	1 N.O. & 1 N.C.	Shielded	1.57 inches (40 mm)	DC Screw	E56ADL40SA
						DC 4-Pin Mini	E56ADL40SAE01 ☹
						DC 4-Pin Micro	E56ADL40SAD01 ☹
Medium Diameter (110 x 110 x 41 mm) 				Unshielded	2 inches (50 mm)	DC Screw	E56ADL50UA
						DC 4-Pin Mini	E56ADL50UAE01 ☹
						DC 4-Pin Micro	E56ADL50UAD01 ☹
Large Diameter (172 x 172 x 68 mm) 				Unshielded	2.75 inches (70 mm)	DC 4-Pin Mini	E56BDL70UAE01 ☹
						DC 4-Pin Micro	E56BDL70UAD01 ☹
				Unshielded	3.94 inches (100 mm)	DC 4-Pin Mini	E56CDL100UAE01 ☹
	DC 4-Pin Micro	E56CDL100UAD01 ☹					

① Includes potentiometer for adjustment of sensing range.

② Autoconfigure technology allows the sensor to automatically adapt to NPN or PNP without user intervention.

☹☹ See listing of compatible connector cables on **Page 3-66**.

☐ Stocked product, typical order quantities guaranteed in stock.

Specifications

	AC/DC 2-Wire			DC 4-Wire		
	Small Diameter	Medium Diameter	Large Diameter	Small Diameter	Medium Diameter	Large Diameter
Operating Voltage	20 – 250V AC, 20 – 60V DC			10 – 42V DC		
Load Current (Max.)	400 mA			300 mA		
Burden Current	—			< 25 mA		
Off-State Leakage	At or Above 0°C: < 1.7 mA Below 0°C: 2.0 mA			< 150 µA per Output		
Voltage Drop	< 10V (5V Nominal)			< 2.5V		
Outputs	N.O. or N.C. (Switch Selectable)	N.O. or N.C. by Model		1 N.O. / 1 N.C. (Complementary)		
Sensing Range (Max.)	50 mm	70 mm	100 mm	50 mm	70 mm	100 mm
Range Adjustment	Not adjustable	Potentiometer adjustable down to 50% of rated maximum range		Not adjustable	Potentiometer adjustable down to 50% of rated maximum range	
Standard Target Size (Mild Steel)	150 mm	210 mm	300 mm	150 mm	210 mm	300 mm
Frequency of Operation	30 Hz	10 Hz		100 Hz	20 Hz	
Repeatability	< 2%					
Hysteresis (Max.)	10 – 15%					
Time Delay Before Availability	300 mS					
Circuit Protection	Short Circuit Protection with Auto-Reset					
Operating Temperature	-25° to +70°C (-13° to + 158°F)					
Temperature Drift	±10%					
Enclosure Rating	NEMA 4, 4X, 6, 6P, 12 and 13 (IP67)					
Approvals	CE					
Indicator LEDs	Output Status			Green: Power Red: Output Status		
Materials of Construction	PPS Housing Aluminum Baseplate on medium and large models					

Approximate Dimensions in Inches (mm)

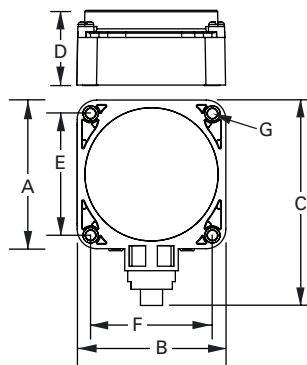

Model	A (Depth)	B (Width)	C (Depth)	D (Height)	Mounting		
					E	F	G (dia.)
Small Diameter Models							
Micro Connector	3.13 (79.0)	3.13 (79.0)	4.32 (110.0)	1.54 (39.0)	2.56 (65.0)	2.56 (65.0)	0.21 (5.0)
Mini Connector			4.67 (119.0)				
Screw Terminal			3.87 (92.0)				
Medium Diameter Models							
Micro Connector	4.35 (110.0)	4.35 (110.0)	4.94 (125.4)	1.63 (41.0)	3.625 (92.0)	3.625 (92.0)	0.218 (5.5)
Mini Connector			5.29 (134.4)				
Large Diameter Models							
Micro Connector	6.75 (171.5)	6.75 (171.5)	7.26 (184.4)	2.66 (67.5)	5.875 (149.0)	5.875 (149.0)	0.266 (7.0)
Mini Connector			7.61 (193.3)				